



picoBoo FI-103

OPERATING MANUAL



471 Maybank Avenue
Toronto, Ontario M6N 3S7
Tel: 905-803-9274 Fax: 647-439-1470
www.frightideas.com

Recording Animation

If you are having problems recording and are using a motion sensor for a trigger, disconnect the motion sensor and read ahead to learn how to change your input to normally-open. Change back to normally-closed when you're done.

1. Press "REC", the red light will turn on and recording begins.
2. Press the "1" & "2" output buttons to turn on the outputs as you want them to turn on. You can press each button as many times as you want or hold them for as long as you want, whatever you do on those buttons will be recorded for up to 2 minutes.
3. Press "REC" again to stop recording, the scene is automatically saved. Press "2" or trigger the input to preview the scene.

Inputs

In order for the picoBoo to be able to read your trigger properly you must set the contact type. If your trigger is normally-open then you can skip this step as it's the default setting. If it's normally-closed then you must program the picoBoo accordingly. If you are unsure of your trigger's contact-type use the test below to find out.

Determining your Trigger's Contact-Type

Connect your trigger/sensor using the diagrams below. Power up the picoBoo, if it's a motion sensor wait a few minutes for it to warm up. Trip your sensor/trigger as you watch the yellow input light on the picoBoo, if the yellow light turns ON it's a N.O. contact, if it turns off it's N.C., if it does nothing there is a wiring problem.

Setting the input type to Normally Closed (N.C.) or Normally Open (N.O.)

1. Power down the picoBoo
2. Hold the "1" AND "2" buttons to set to N.C. or just "1" to set to N.O.
3. Power up the picoBoo while holding the button(s)
4. When the red light flashes twice you can let go of the buttons.

Common Contact Types	
- Pressure Pad	NO
- Push Button	
- Cheap Motion Sensor	
- Alarm-quality PIR Motion Sensor	NC

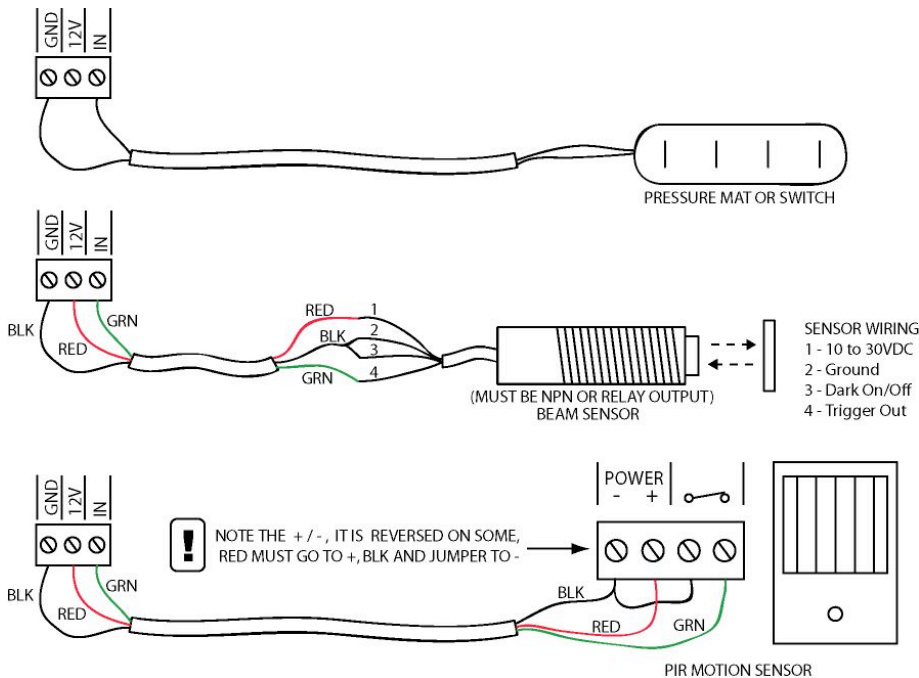

Terminal Block Outputs

The outputs are simple contact closures, which can be wired N.O. or N.C. The outputs do not supply voltage, if you would like them to you must wire voltage into one of the terminals. If you plan to use 120 volts then it is your responsibility to take the appropriate safety precautions with wiring. Each relay can handle 10 amps @ 125 volts.

Controlling Solenoids or Large Relays

Solenoids and Large Relays create a lot of interference, this can wreak havoc to nearby electronic devices. If your picoBoo or other nearby electronics start acting funky when controlling one of these devices this is most likely your problem. The solution depends on whether you are using AC or DC solenoids.

AC Solenoids

A high voltage capacitor must be installed to absorb the feedback. The best place to install it is as close as possible to the solenoid, if that's not possible then across the terminal block may work as well.

Radio Shack part numbers: 272-1053 or 272-1051

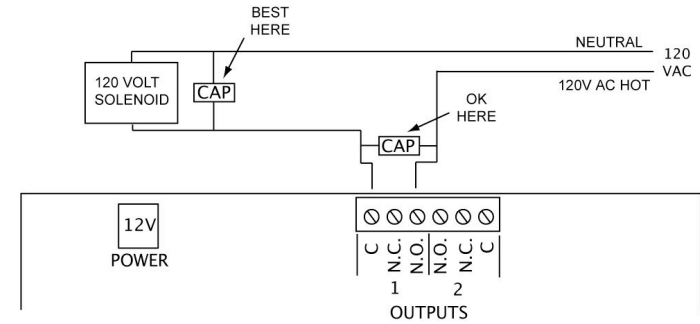

DC Solenoids

A diode must be installed across the solenoid. Note the orientation of the diode, using the line on the one side as a guide. Locate the diode as close to the solenoid as possible. A standard 1N4001 – 1N4004 diode will work fine, available for less than a dollar at your local Radio Shack.

Radio Shack part number: 276-1103 or 276-1102

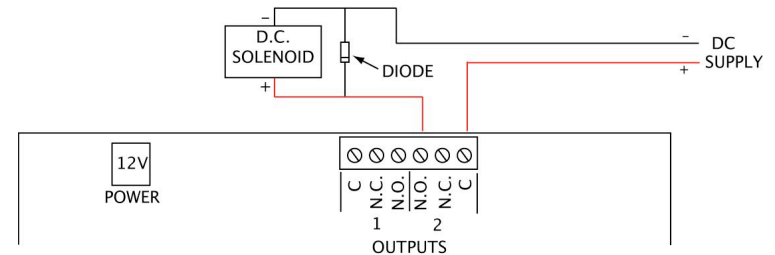

Setting Write-Protect

Once the picoBoo is programmed to your liking you can write-protect it to make sure the "REC" button is not accidentally pressed thus changing or deleting your program. The write-protect setting toggles on and off, change it by powering down your picoBoo for a few seconds then powering it back up holding only the "2" button.

Troubleshooting

Problem	Solution
- "REC" light keeps flashing when powered up - Motion sensor won't trigger scare	- The motion sensor is warming up, wait 2 minutes - Input is set to normally-closed when it should be normally-open, read "Inputs"
- Scare loops after about 2 minutes	- Input is set to normally-open when it should be normally-closed, read "Inputs"
- Can't record animation	- picoBoo is write-protected - Audio source still connected to Line-In, remove it